

**2001–2015 MINIVAN CHILD PASSENGER SAFETY
SUPPLEMENT**

Chrysler/Dodge



FIAT CHRYSLER AUTOMOBILES

TABLE OF CONTENTS

1	INTRODUCTION	2
2	INSTALLING CHILD RESTRAINTS	4
3	OPERATING INSTRUCTIONS FOR BUILT-IN (INTEGRATED) CHILD RESTRAINT — IF EQUIPPED ...	8
4	INSTALLING CHILD RESTRAINTS IN YOUR VEHICLE	13
5	INDEX	29

INTRODUCTION

CONTENTS

- Welcome From FCA US LLC.3
- How To Use This Supplement.3

Welcome From FCA US LLC

If you have opened this guide, chances are you have questions about the correct use of child restraints in your vehicle. This supplement has been developed to help answer those questions. This document is intended to supplement the information provided in the Owner's Manual and/or User Guide that came with your vehicle. If you no longer have your Owner's Manual or User Guide, please visit www.techauthority.com to order a replacement.

This guide does not cover the proper selection of car seats or the proper usage of car seats. For questions about car seat selection and usage, please visit NHTSA's website: <http://www.safercar.gov/parents/Car-Seat-Safety.htm>. This website also features videos showing step-by-step installation of different types of car seats.

How To Use This Supplement

Section two of this supplement, "Installing Child Restraints," provides general information about the installation of child restraints in vehicles. It provides step-by-step instructions for installing a car seat using either the seat belts or the LATCH anchorages in your vehicle. Read this section to learn how to:

- Locate LATCH and Tether anchorages in vehicles
- Install a car seat using LATCH
- Install a car seat using seat belts

This section also includes key warnings about the misuse of car seats. Read and follow all of these warnings when transporting children in your vehicle.

Section three provides instructions for using the built-in (integrated) child restraint, if your vehicle is equipped with one.

Section four provides information that is specific for the Model Year, Make and Model of your vehicle. To use this section, first refer to the table of contents to find your vehicle. Some listings will include a range of model years. Click on the section for your vehicle to find information about:

- Locating the LATCH anchorages in your vehicle
- Frequently asked questions about LATCH
- Directions for locating and using the Tether Anchorages in your vehicle
- Seat belt systems in your vehicle for installing car seats
- Frequently asked questions about seat belts and car seats

Copyright ©2015 FCA US LLC

INSTALLING CHILD RESTRAINTS

CONTENTS

■ Installing Child Restraints	5	■ Installing Child Restraints Using The Vehicle Seat Belt	6
■ Rear-Facing Car Seats And Air Bags	5	■ Installing A Child Restraint With A Switchable Automatic Locking Retractor (ALR) — If Equipped	6
■ Lower Anchors And Tethers For Children (LATCH) Restraint System	5	■ Installing A Child Restraint With A Cinching Latch Plate (CINCH) — If Equipped	6
■ Locating The LATCH And Tether Anchorages	5	■ Installing Child Restraints Using The Top Tether Anchorage	7
■ Installing Child Restraints Using The LATCH Lower Anchorages	5		
■ How To Stow An Unused ALR Seat Belt	6		

Installing Child Restraints

Children 12 years or younger should ride properly buckled up in a rear seat, if available. According to crash statistics, children are safer when properly restrained in the rear seats rather than in the front.

Every state in the United States and all Canadian provinces require that small children ride in proper restraint systems. This is the law, and you can be prosecuted for ignoring it.

NOTE: For additional information, refer to www.seatcheck.org or call 1-866-SEATCHECK. Canadian residents should refer to Transport Canada's website for additional information: <http://www.tc.gc.ca/eng/motorvehiclesafety/safedrivers-childsafety-index-53.htm>

Rear-Facing Car Seats And Air Bags

WARNING!

- Never place a rear-facing child restraint in front of an air bag. A deploying passenger Advanced Front Air Bag can cause death or serious injury to a child 12 years or younger, including a child in a rear-facing child restraint.
- Only use a rear-facing child restraint in a vehicle with a rear seat.

Lower Anchors And Tethers For Children (LATCH) Restraint System



022668173

Your vehicle is equipped with the child restraint anchorage system called LATCH, which stands for Lower Anchors and Tethers for Children. The LATCH system has three vehicle anchor points for installing LATCH-equipped child seats. There are two lower anchorages located at the back of the seat cushion where it meets the seatback and one top tether anchorage located behind the seating position. These anchorages are used to install LATCH-equipped child seats without using the vehicle's seat belts. Some seating positions may have a top tether anchorage but no lower anchorages. In these seating positions, the seat belt must be used with the top tether anchorage to install the child restraint.

NOTE: The LATCH system was phased into vehicles during the 2000–2002 model years. Certain 2000 and 2001 model year vehicles did not feature lower anchorages. These vehicles had tether anchorages only. See the section “LATCH and Tethers in Your Vehicle” for more information.

Locating The LATCH And Tether Anchorages

The lower anchorages are round bars that are found at the rear of the seat cushion where it meets the seatback. If the bars are not readily visible, they are located below the anchorage symbols on the seatback (if equipped). You will easily feel them if you run your finger along the gap between the seatback and seat cushion.



There are tether strap anchorages behind the rear seating positions located on the back of the seat or near the floor. See the section “LATCH and Tethers in Your Vehicle” for more information about finding tethers in your vehicle, as not all seating positions have a tether anchorage and some may be hidden behind a panel or cover.

Always follow the directions of the child restraint manufacturer when installing your child restraint. Not all child restraint systems will be installed as described here.

Installing Child Restraints Using The LATCH Lower Anchorages

1. If the selected seating position has a Switchable Automatic Locking Retractor (ALR) seat belt, stow the seat belt, following the instructions below. See the section “Seat Belt Systems in Your Vehicle” to check what type of seat belt each seating position has.
2. Loosen the adjusters on the lower straps and on the tether strap of the child seat so that you can more easily attach the hooks or connectors to the vehicle anchorages.
3. Place the child seat between the lower anchorages for that seating position. For some second row seats, you may need to recline the seat and/or raise the head restraint to get a better fit. If the rear seat can be moved forward and rearward in the vehicle, you may wish to move it to its rear-most position to make room for the child seat. You may also move the front seat forward to allow more room for the child seat.
4. Attach the lower hooks or connectors of the child restraint to the lower anchorages in the selected seating position.
5. If the child restraint has a tether strap, connect it to the top tether anchorage. See the section “LATCH and Tethers in Your Vehicle” for directions to attach a tether anchor.
6. Tighten all of the straps as you push the child restraint rearward and downward into the seat. Remove slack in the straps according to the child restraint manufacturer's instructions.
7. Test that the child restraint is installed tightly by pulling back and forth on the child seat at the belt path. It should not move more than 1 inch (25.4 mm) in any direction.

How To Stow An Unused ALR Seat Belt

When using the LATCH attaching system to install a child restraint, stow all ALR seat belts that are not being used by other occupants or being used to secure child restraints. An unused belt could injure a child if they play with it and accidentally lock the seat belt retractor. Before installing a child restraint using the LATCH system, buckle the seat belt behind the child restraint and out of the child's reach. If the buckled seat belt interferes with the child restraint installation, instead of buckling it behind the child restraint, route the seat belt through the child restraint belt path and then buckle it. Do not lock the seat belt. Remind all children in the vehicle that the seat belts are not toys and that they should not play with them.

WARNING!

- **Improper installation of a child restraint to the LATCH anchorages can lead to failure of the restraint. The child could be badly injured or killed. Follow the child restraint manufacturer's directions exactly when installing an infant or child restraint.**
- **Child restraint anchorages are designed to withstand only those loads imposed by correctly-fitted child restraints. Under no circumstances are they to be used for adult seat belts, harnesses, or for attaching other items or equipment to the vehicle.**

Installing Child Restraints Using The Vehicle Seat Belt

The seat belts in the passenger seating positions are equipped with either a Switchable Automatic Locking Retractor (ALR) or a cinching latch plate or both. Both types of seat belts are designed to keep the lap portion of the seat belt tight around the child restraint so that it is not necessary to use a locking clip.

The ALR retractor can be "switched" into a locked mode by pulling all of the webbing out of the retractor and then letting the webbing retract back into the retractor. If it is locked, the ALR will make a clicking noise while the webbing is pulled back into the retractor. For additional information on ALR, refer to the section "Seat Belt Systems in Your Vehicle." The cinching latch plate is designed to hold the lap portion of the seat belt tight when webbing is pulled tight and straight through a child restraint's belt path.

When installing a forward-facing child restraint, always use the tether anchor up to the maximum weight allowed. See the section "LATCH and Tethers in Your Vehicle" for more information about LATCH weight limits.

Installing A Child Restraint With A Switchable Automatic Locking Retractor (ALR) — If Equipped

1. Place the child seat in the center of the seating position. For some second row seats, you may need to recline the seat and/or raise the head restraint to get a better fit. If the rear seat can be moved forward and rearward in the

vehicle, you may wish to move it to its rear-most position to make room for the child seat. You may also move the front seat forward to allow more room for the child seat.

2. Pull enough of the seat belt webbing from the retractor to pass it through the belt path of the child restraint. Do not twist the belt webbing in the belt path.
3. Slide the latch plate into the buckle until you hear a "click."
4. Pull on the webbing to make the lap portion tight against the child seat.
5. To lock the seat belt, pull down on the shoulder part of the belt until you have pulled all the seat belt webbing out of the retractor. Then, allow the webbing to retract back into the retractor. As the webbing retracts, you will hear a clicking sound. This means the seat belt is now in the Automatic Locking mode.
6. Try to pull the webbing out of the retractor. If it is locked, you should not be able to pull out any webbing. If the retractor is **not** locked, repeat step 5.
7. Finally, pull up on any excess webbing to tighten the lap portion around the child restraint while you push the child restraint rearward and downward into the vehicle seat.
8. If the child restraint has a top tether strap and the seating position has a top tether anchorage, connect the tether strap to the anchorage and tighten the tether strap. See the section "LATCH and Tethers in Your Vehicle" for directions to attach a tether anchor.
9. Test that the child restraint is installed tightly by pulling back and forth on the child seat at the belt path. It should not move more than 1 inch (25.4 mm) in any direction.

Any seat belt system will loosen with time, so check the belt occasionally, and pull it tight if necessary.

WARNING!

Do not use the Automatic Locking Mode to restrain occupants who are wearing the seat belt or children who are using booster seats. The locked mode is only used to install rear-facing or forward-facing child restraints that have a harness for restraining the child.

Installing A Child Restraint With A Cinching Latch Plate (CINCH) — If Equipped

1. Place the child seat in the center of the seating position. For some second row seats, you may need to recline the seat and/or raise the head restraint to get a better fit. If the rear seat can be moved forward and rearward in the vehicle, you may wish to move it to its rear-most position to make room for the child seat. You may also move the front seat forward to allow more room for the child seat.
2. Next, pull enough of the seat belt webbing from the retractor to pass it through the belt path of the child restraint. Do not twist the belt webbing in the belt path.
3. Slide the latch plate into the buckle until you hear a "click."

4. Finally, pull up on any excess webbing to tighten the lap portion around the child restraint while you push the child restraint rearward and downward into the vehicle seat.
5. If the child restraint has a top tether strap and the seating position has a top tether anchorage, connect the tether strap to the anchorage and tighten the tether strap. See the section "LATCH and Tethers in Your Vehicle" for directions to attach a tether anchor.
6. Test that the child restraint is installed tightly by pulling back and forth on the child seat at the belt path. It should not move more than 1 inch (25.4 mm) in any direction.

Any seat belt system will loosen with time, so check the belt occasionally, and pull it tight if necessary.

If the buckle or the cinching latch plate is too close to the belt path opening of the child restraint, you may have trouble tightening the seat belt. If this happens, disconnect the latch plate from the buckle and twist the short buckle-end belt up to three full turns to shorten it. Insert the latch plate into the buckle with the release button facing out, away from the child restraint. Repeat steps 4 to 6, above, to complete the installation of the child restraint.

If the belt still cannot be tightened after you shorten the buckle, disconnect the latch plate from the buckle, turn the buckle around one half turn, and insert the latch plate into the buckle again. If you still cannot make the child restraint installation tight, try a different seating position.

Installing Child Restraints Using The Top Tether Anchorage

See the section "LATCH and Tethers in Your Vehicle" for specific instructions for using the tether anchorages in your vehicle.

WARNING!

Do not attach a tether strap for a rear-facing car seat to any location in front of the car seat, including the seat frame or a tether anchorage. Only attach the tether strap of a rear-facing car seat to the tether anchorage that is approved for that seating position, located behind the top of the vehicle seat. See the section "LATCH and Tethers in Your Vehicle" for the location of approved tether anchorages in your vehicle.

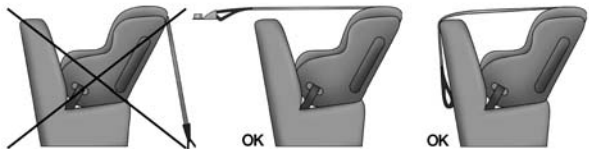

0226047162

WARNING!

- In a collision, an unrestrained child, even a tiny baby, can become a projectile inside the vehicle. The force required to hold even an infant on your lap could become so great that you could not hold the child, no matter how strong you are. The child and others could be severely injured or killed. Any child riding in your vehicle should be in a proper restraint for the child's size.
- Never place a rear-facing child restraint in front of an air bag. A deploying Passenger Advanced Front Air Bag can cause death or serious injury to a child 12 years or younger, including a child in a rear-facing child restraint.
- Only use a rear-facing child restraint in a vehicle with a rear seat.
- Improper installation of a child restraint to the LATCH anchorages can lead to failure of an infant or child restraint. The child could be severely injured or killed. Follow the manufacturer's directions exactly when installing an infant or child restraint.
- An incorrectly anchored tether strap could lead to increased head motion and possible injury to the child. Use only the anchor positions directly behind the child seat to secure a child restraint top tether strap.
- If your vehicle is equipped with a split rear seat, make sure the tether strap does not slip into the opening between the seatbacks as you remove slack in the strap.

WARNING!

If your vehicle is equipped with in-floor storage, do not install a rear-facing car seat using a rear support leg in this vehicle. The floor of this vehicle is not designed to manage the crash forces of this type of car seat. In a crash, the support leg may not function as it was designed by the car seat manufacturer, and your child may be more severely injured as a result.



0226047161

OPERATING INSTRUCTIONS FOR BUILT-IN (INTEGRATED) CHILD RESTRAINT — IF EQUIPPED

CONTENTS

■ Operating Instructions For Built-In (Integrated) Child Restraint — If Equipped	9	■ To Remove The Child:	11
■ Who Should Use This Child Seat:	9	■ To Clean The Removable Pad:	11
■ Who Should Use Adult Seat And Belts:	9	■ To Recline The Child Seat:	11
■ To Open The Child Restraint:	9	■ Rear Bucket Seats Equipped With Child Restraint . . .	12
■ To Secure The Child:	10		

Operating Instructions For Built-In (Integrated) Child Restraint — If Equipped

Refer to the picture below to become familiar with the parts of the child seat and five-point seat belts. This child restraint system conforms to U.S. Federal Motor Vehicle Safety Standard 213 and Canada Motor Vehicle Safety Standard No. 213.4.



Figure 1

- A – Removable Pad
- B – Buckle
- C – Seat Belt Latch Plates
- D – Buckle Release Button
- E – Release Handle
- F – Shoulder Belt Adjustment Strap
- G – Shoulder Belt Clip

It is important to use an approved rear-facing infant restraint for a full year to allow the neck and spine to develop enough to support the weight of the child’s head in the event of a collision.

WARNING!

Failure to follow these instructions can result in your child striking the vehicle’s interior during a sudden stop or crash. Snugly adjust the belts provided with the child restraint around your child.

Who Should Use This Child Seat:

Children 10-23 kg (22-50 pounds).

This integrated child seat is designed for use only by children who weigh between 10 and 23 kg (22 and 50 pounds) and whose shoulders are not above the shoulder belt slot position and who are capable of sitting upright alone (Figure 2).



Figure 2

0226074094

Who Should Use Adult Seat And Belts:

Children over 23 kg (50 pounds) and adults.

Children over 23 kg (50 pounds) should find that the adult seat when used with the adult belts equipped with adjustable upper anchorages provide a safe and comfortable fit (Figure 3).



Figure 3

0226074095

To Open The Child Restraint:

Grasp the upper portion (leg rest pad) (Figure 4) and lower the child seat cushion.



Figure 4

0226074096

WARNING!

Do not use this cushion as a booster chair with adult seat belts. Serious or fatal injury to the child could result in the event of an accident.

To Secure The Child:

1. Before placing the child in the seat, add slack to the shoulder belts. Release the seat belts by pulling up on the shoulder belt adjustment strap located at the top of the seat, then pull on the seat belts (Figure 5).

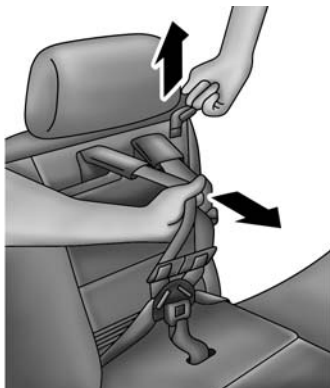

Figure 5

0226074097

WARNING!

Whenever a child is using the integrated child seat, be sure that the head restraint is installed in the fully lowered position or personal injury may result in the event of an accident.

2. Place the child into the child seat and put a shoulder belt over each shoulder. Insert both seat belt latch plates into the buckle and pull up on them to make sure they are firmly latched (Figure 6).



Figure 6

0226074098

NOTE: Be sure that the seat belt buckle is free of foreign objects that may prevent you from properly latching the latch plates. If an object is in the opening, and cannot be removed, see your dealer for service immediately.

3. Fasten the two halves of the shoulder belt clip together and put it 5-8 cm (2-3 inches) below the child's chin. The purpose of the clip is to keep the shoulder belts positioned correctly on the shoulders (Figure 7).



Figure 7

0226074099

4. Pull the shoulder belt adjustment strap firmly until the shoulder belts are tight against the child's shoulders. You should not be able to put more than two fingers between the shoulder belts and the child's chest (Figure 8).



Figure 8

0226074100

A ratcheting sound should be heard as the excess belt material returns to the retractor and belts become secure around the child.

NOTE: Once properly adjusted there is no need to release the seat belts until a change in clothing or height or weight occurs.

WARNING!

- A frayed or torn child restraint belt could rip apart in a collision and leave your child with no protection. Inspect the belt system periodically, checking for cuts, frays, or loose parts. Damaged parts must be replaced immediately.
- Do not disassemble or modify the system.
- Child restraint belt systems must be replaced after a collision if they have been damaged (bent buckle or 5-point connector, torn webbing, etc.). Similarly, the child restraint-equipped bench or bucket seat must be replaced after a collision if it is damaged (bent or broken seat frame, etc.).

To Remove The Child:

1. To release the child from the seat belts, separate the halves of the shoulder belt clip. Then push the red release button in the buckle. Move the shoulder belts to the side and remove the child from the seat.
2. Return the buckle assembly to its lowered position for stowage after each use (Figure 9). This will allow the child seat to be neatly folded when not in use.



Figure 9

0226074101

To Clean The Removable Pad:

The cloth pad is attached to the seat frame with a fastener strip and can be easily removed (Figure 10) and machine washed according to directions on the pad.



Figure 10

0226074102

To replace the removable pad, align the opening in the pad with the crotch belt and buckle and press the pad into place (Figure 11).



Figure 11

0226074103

CAUTION!

Failure to follow the washing instructions on the removable pad may result in premature wear.

To Recline The Child Seat:

1. Unlatch the recliner by lifting the release handle (Figure 12).

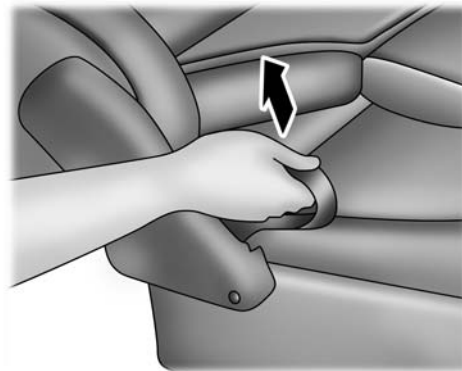

Figure 12

0226074104

2. Recline the seat by pushing rearward on the seat back (Figure 13).



Figure 13

0226074105

NOTE: The seat is equipped with an interlock mechanism to prevent the seat back from being folded while the child seat is open (Figure 14). Returning the child seat(s) to their stowed position(s) will allow the seat back to be folded.



Figure 14

0226074106

Rear Bucket Seats Equipped With Child Restraint

WARNING!

The rear bucket seats can be tilted forward for easy access to the third seat or rear cargo area. Do not tilt the seat forward when a child is using the child restraint equipped seat or personal injury may result.



Figure 15

0226074107

INSTALLING CHILD RESTRAINTS IN YOUR VEHICLE

CONTENTS

<ul style="list-style-type: none"> ■ 2001 MODEL YEAR: CHRYSLER TOWN & COUNTRY/CHRYSLER VOYAGER/DODGE CARAVAN/DODGE GRAND CARAVAN14 □ LATCH And Tethers In Your Vehicle14 □ Center Seat LATCH15 □ Connecting The Top Tether Strap (With Either Lower Anchors Or Vehicle Seat Belt)15 □ Seat Belt Systems In Your Vehicle16 ■ 2002–2004 MODEL YEARS: CHRYSLER TOWN & COUNTRY/CHRYSLER VOYAGER/DODGE CARAVAN/DODGE GRAND CARAVAN17 □ LATCH And Tethers In Your Vehicle17 □ Connecting The Top Tether Strap (With Either Lower Anchors Or Vehicle Seat Belt)18 □ Seat Belt Systems In Your Vehicle19 ■ 2005–2007 MODEL YEARS: CHRYSLER TOWN & COUNTRY/DODGE CARAVAN/DODGE GRAND CARAVAN20 □ LATCH And Tethers In Your Vehicle20 	<ul style="list-style-type: none"> □ Center Seat LATCH — With Stow 'n Go22 □ Connecting The Top Tether Strap (With Either Lower Anchors Or Vehicle Seat Belt)22 □ Seat Belt Systems In Your Vehicle23 ■ 2008–2015 MODEL YEARS: CHRYSLER TOWN & COUNTRY/DODGE GRAND CARAVAN24 □ LATCH And Tethers In Your Vehicle24 □ Center Seat LATCH26 □ Connecting The Top Tether Strap (With Either Lower Anchors Or Vehicle Seat Belt)26 □ Seat Belt Systems In Your Vehicle27 □ Integrated Child Booster Seat — If Equipped28
--	--

2001 MODEL YEAR: CHRYSLER TOWN & COUNTRY/CHRYSLER VOYAGER/DODGE CARAVAN/
DODGE GRAND CARAVAN

LATCH And Tethers In Your Vehicle

LATCH Positions For Installing Child Restraints In This Vehicle

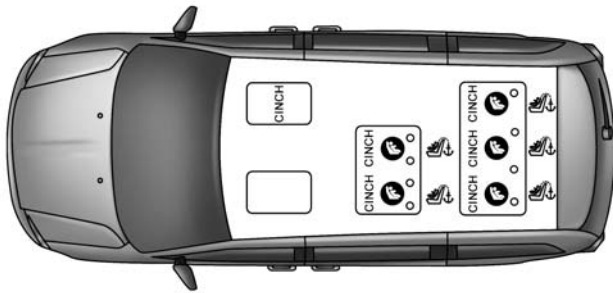

0226074397

2nd Row Bench Seat

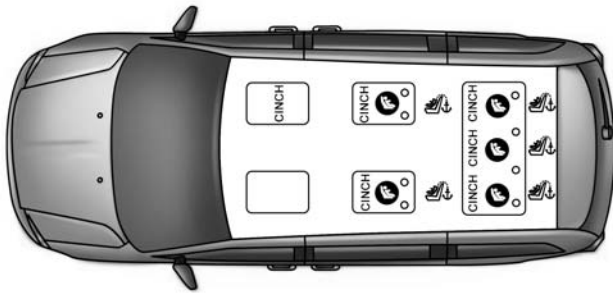

0226074402

2nd Row Quad Seating

- Lower Anchorage Symbol (2 Anchorages Per Seating Position)
- Top Tether Anchorage Symbol

Locating The LATCH Lower Anchorages In This Vehicle



0226074419

2nd Row Bench Seat LATCH Lower Anchorages

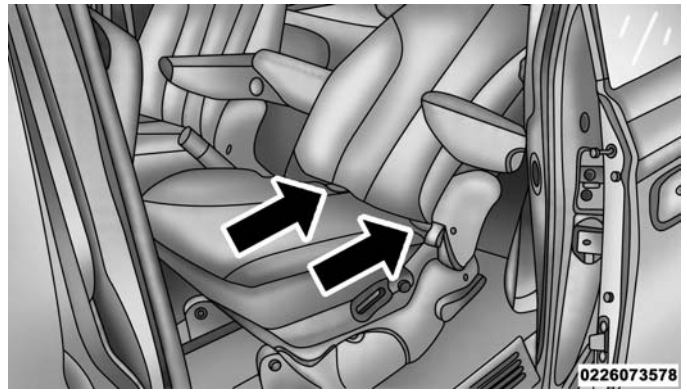

0226073578

2nd Row Quad Seat LATCH Lower Anchorages

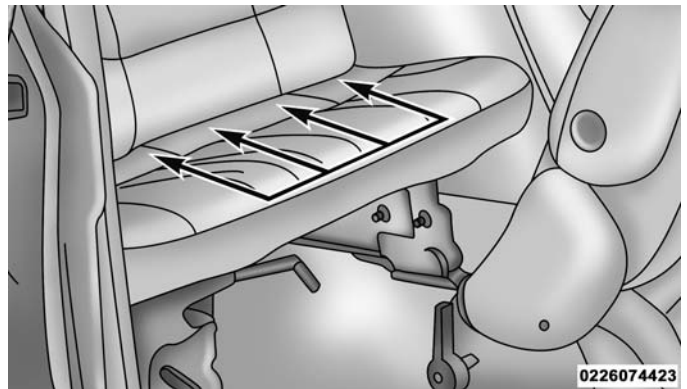

0226074423

3rd Row Bench Seat LATCH Lower Anchorages

Locating The Tether Anchorages In This Vehicle

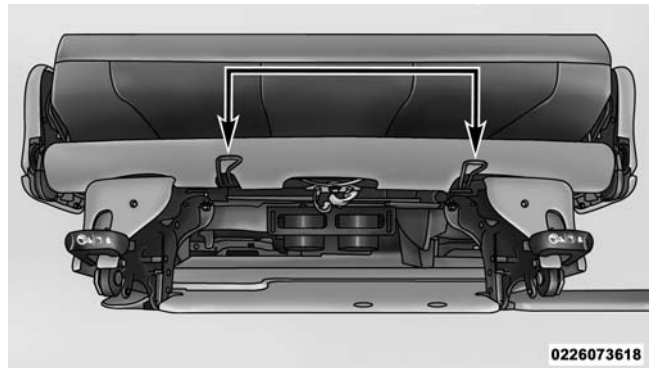

0226073618

2nd Row Bench Seat Tether Strap Anchorages

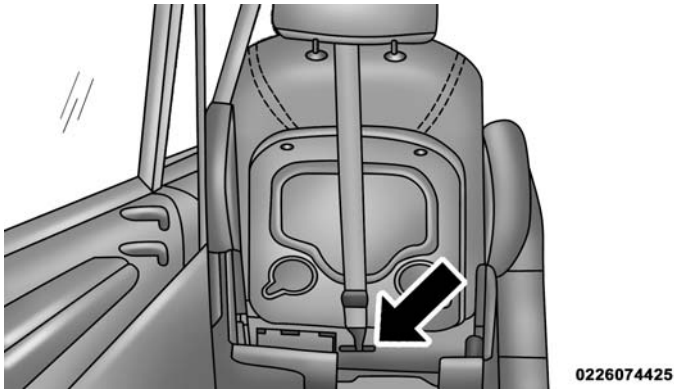

2nd Row Quad Tether Strap Anchorage

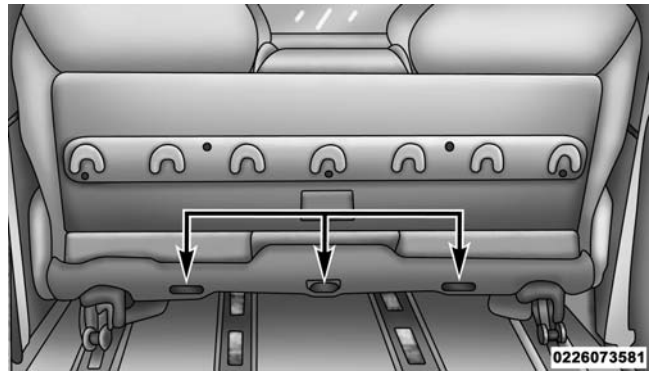

3rd Row Bench Seat Tether Strap Anchorages

Frequently Asked Questions About LATCH		
What is the weight limit (child’s weight + weight of the child restraint) for using the LATCH anchorage system to attach the child restraint?	65 pounds	Use the LATCH anchorage system until the combined weight of the child and the child restraint is 65 lbs (29.5 kg). Use the seat belt and tether anchor instead of the LATCH system once the combined weight is more than 65 lbs (29.5 kg).
Can the LATCH anchorages and the seat belt be used together to attach a rear-facing or forward-facing child restraint?	No	Do not use the seat belt when you use the LATCH anchorage system to attach a rear-facing or forward-facing child restraint.
Can two child restraints be attached using a common lower LATCH anchorage?	No	Never “share” a LATCH anchorage with two or more child restraints. If the center position does not have dedicated LATCH lower anchorages, use the seat belt to install a child seat in the center position next to a child seat using the LATCH anchorages in an outboard position.
Can the rear-facing child restraint touch the back of the front passenger seat?	Yes	The child seat may touch the back of the front passenger seat if the child restraint manufacturer also allows contact. See your child restraint Owner’s Manual for more information.
Can the head restraints be removed?	Yes	All adjustable head restraints may be removed.

Center Seat LATCH

To install a child restraint in the center position using the LATCH anchorages, attach the lower hooks or connectors on the child restraint to the two inner bars in the row. If LATCH is used for the center seating position, do not use the lower anchorages in the outboard positions.

If a child restraint installed in the center position blocks the seat belt webbing or buckle for the outboard position, do not use that outboard position. If a child seat in the center position blocks the outboard LATCH anchors or seat belt, do not install a child seat in that outboard position.

WARNING!
Never use the same lower anchorage to attach more than one child restraint. Please refer to “Installing The LATCH-Compatible Child Restraint System” for typical installation instructions.

Connecting The Top Tether Strap (With Either Lower Anchors Or Vehicle Seat Belt)

When installing a forward-facing child restraint, always secure the top tether strap, up to the tether anchor weight limit, whether the child restraint is installed with the lower anchors or the vehicle seat belt.

1. Look behind the seating position where you plan to install the child restraint to find the tether anchorage. You may need to move the seat forward to provide better access to the tether anchorage. If there is no top tether anchorage for that seating position, move the child restraint to another position in the vehicle if one is available.
2. Route the tether strap to provide the most direct path for the strap between the anchor and the child seat. If your vehicle is equipped with adjustable rear head restraints, raise the head restraint, and where possible, route the tether strap under the head restraint and between the two posts. If not possible, lower the head restraint and pass the tether strap around the outboard side of the head restraint.

3. Attach the tether strap hook of the child restraint to the top tether anchorage.
4. Remove slack in the tether strap according to the child restraint manufacturer’s instructions.

WARNING!

- An incorrectly anchored tether strap could lead to increased head motion and possible injury to the child. Use only the anchorage position directly behind the child seat to secure a child restraint top tether strap.
- If your vehicle is equipped with a split rear seat, make sure the tether strap does not slip into the opening between the seatbacks as you remove slack in the strap.

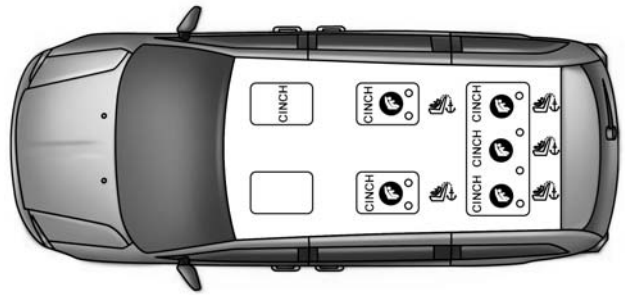

0226074402

2nd Row Quad Seating – All Positions CINCH,
3rd Center CINCH Lap Belt

Seat Belt Systems In Your Vehicle

Lap/Shoulder Belt Systems For Installing Child Restraints In This Vehicle

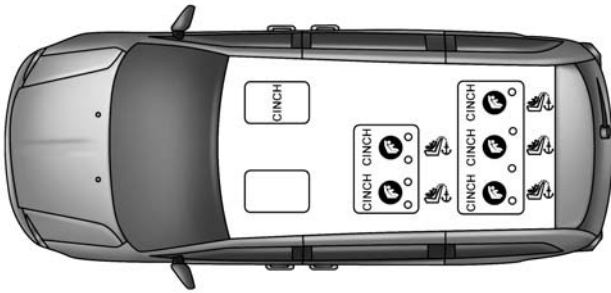

0226074397

2nd Row Bench Seat – All Positions CINCH,
3rd Center CINCH Lap Belt

Frequently Asked Questions About Seat Belts And Car Seats		
What is the weight limit (child’s weight + weight of the child restraint) for using the Tether Anchor with the seat belt to attach a forward facing child restraint?	Weight limit of the Child Restraint	Always use the tether anchor when using the seat belt to install a forward facing child restraint, up to the recommended weight limit of the child restraint.
Can the rear-facing child restraint touch the back of the front passenger seat?	Yes	The child seat may touch the back of the front passenger seat if the child restraint manufacturer also allows contact. See your child restraint Owner’s Manual for more information.
Can the head restraints be removed?	Yes	All adjustable head restraints may be removed.
Can the buckle stalk be twisted to tighten the seat belt against the seat belt path of the child restraint?	Yes	In positions with cinching latch plates (CINCH), the buckle stalk may be twisted up to 3 full turns.

2002–2004 MODEL YEARS: CHRYSLER TOWN & COUNTRY/CHRYSLER VOYAGER/DODGE CARAVAN/
DODGE GRAND CARAVAN

LATCH And Tethers In Your Vehicle

LATCH Positions For Installing Child Restraints In This Vehicle

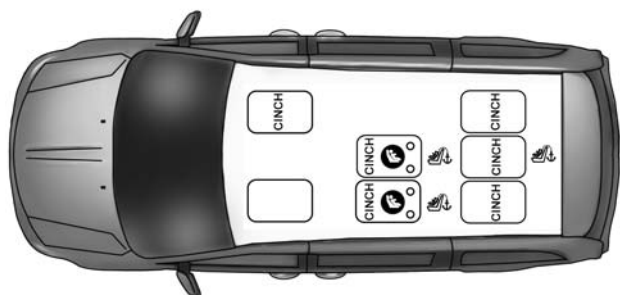

0226074934

2nd Row Bench Seat

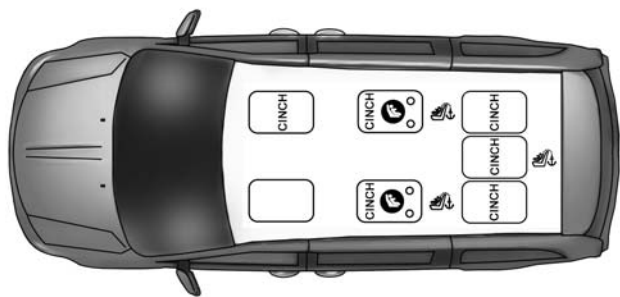

0226074936

2nd Row Quad Seating

- Lower Anchorage Symbol (2 Anchorages Per Seating Position)
- Top Tether Anchorage Symbol

Locating the LATCH Lower Anchorages In This Vehicle



0226074419

2nd Row Bench Seat LATCH Lower Anchorages

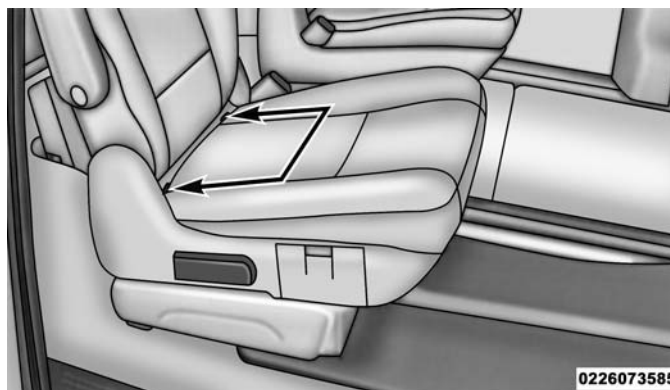

0226073585

2nd Row Quad Seat LATCH Lower Anchorages

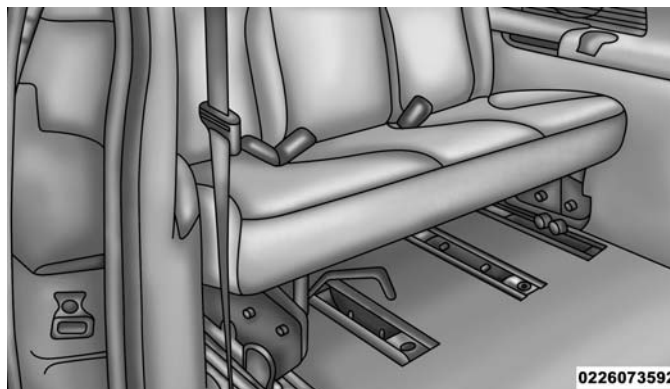

0226073592

3rd Row Bench Seat Has No LATCH Lower Anchorages

Locating The Tether Anchorages In This Vehicle

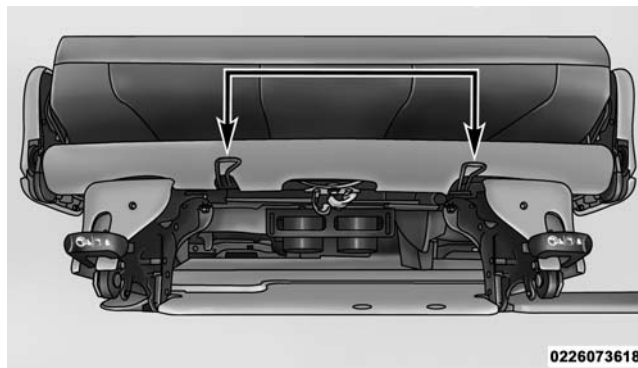

0226073618

2nd Row Bench Seat Tether Strap Anchorages

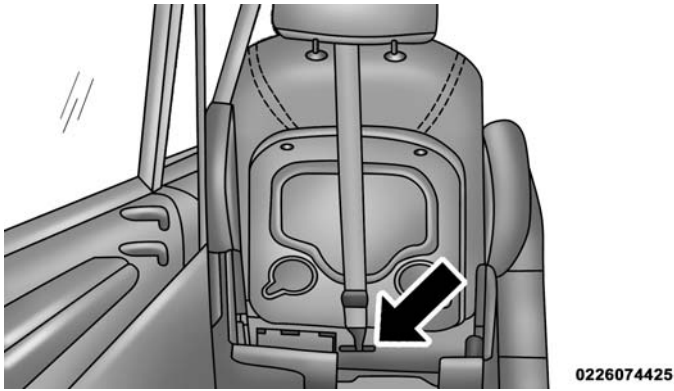

2nd Row Quad Seat Tether Strap Anchorage

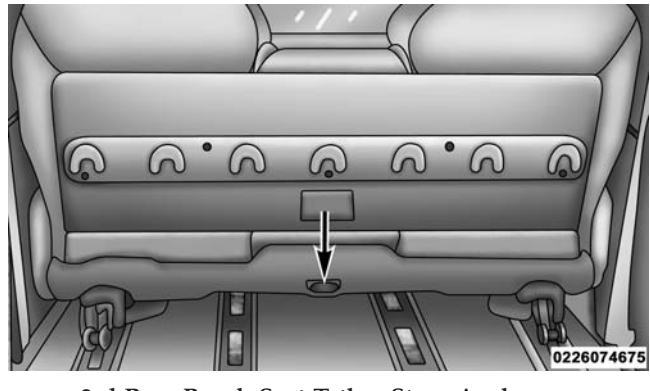

3rd Row Bench Seat Tether Strap Anchorage

Frequently Asked Questions About LATCH

What is the weight limit (child’s weight + weight of the child restraint) for using the LATCH anchorage system to attach the child restraint?	65 pounds	Use the LATCH anchorage system until the combined weight of the child and the child restraint is 65 lbs (29.5 kg). Use the seat belt and tether anchor instead of the LATCH system once the combined weight is more than 65 lbs (29.5 kg).
Can the LATCH anchorages and the seat belt be used together to attach a rear-facing or forward-facing child restraint?	No	Do not use the seat belt when you use the LATCH anchorage system to attach a rear-facing or forward-facing child restraint.
Can two child restraints be attached using a common lower LATCH anchorage?	No	Never “share” a LATCH anchorage with two or more child restraints. If the center position does not have dedicated LATCH lower anchorages, use the seat belt to install a child seat in the center position next to a child seat using the LATCH anchorages in an outboard position.
Can the rear-facing child restraint touch the back of the front passenger seat?	Yes	The child seat may touch the back of the front passenger seat if the child restraint manufacturer also allows contact. See your child restraint Owner’s Manual for more information.
Can the head restraints be removed?	Yes	All adjustable head restraints may be removed.

WARNING!

Never use the same lower anchorage to attach more than one child restraint. Please refer to “Installing The LATCH-Compatible Child Restraint System” for typical installation instructions.

Connecting The Top Tether Strap (With Either Lower Anchors Or Vehicle Seat Belt)

When installing a forward-facing child restraint, always secure the top tether strap, up to the tether anchor weight limit, whether the child restraint is installed with the lower anchors or the vehicle seat belt.

1. Look behind the seating position where you plan to install the child restraint to find the tether anchorage. You may need to move the seat forward to provide better access to the tether anchorage. If there is no top tether anchorage for that seating position, move the child restraint to another position in the vehicle if one is available.

2. Route the tether strap to provide the most direct path for the strap between the anchor and the child seat. If your vehicle is equipped with adjustable rear head restraints, raise the head restraint, and where possible, route the tether strap under the head restraint and between the two posts. If not possible, lower the head restraint and pass the tether strap around the outboard side of the head restraint.
3. Attach the tether strap hook of the child restraint to the top tether anchorage.
4. Remove slack in the tether strap according to the child restraint manufacturer’s instructions.

WARNING!

- An incorrectly anchored tether strap could lead to increased head motion and possible injury to the child. Use only the anchorage position directly behind the child seat to secure a child restraint top tether strap.
- If your vehicle is equipped with a split rear seat, make sure the tether strap does not slip into the opening between the seatbacks as you remove slack in the strap.

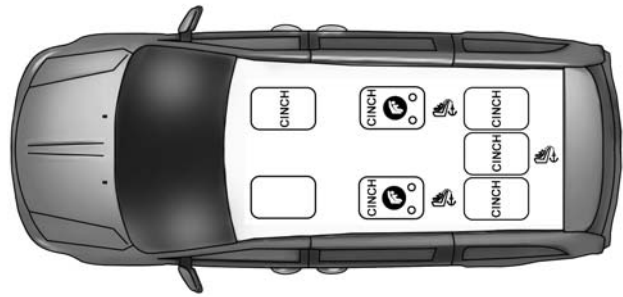

0226074936

2nd Row Quad Seating – All Positions CINCH, 3rd Center CINCH Lap Belt

Seat Belt Systems In Your Vehicle

Lap/Shoulder Belt Systems For Installing Child Restraints In This Vehicle

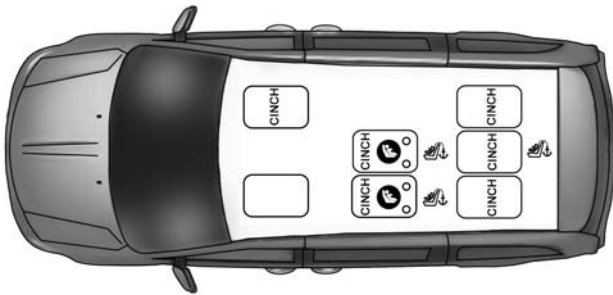

0226074934

2nd Row Bench Seat – All Positions CINCH, 3rd Center CINCH Lap Belt

Frequently Asked Questions About Seat Belts And Car Seats

What is the weight limit (child’s weight + weight of the child restraint) for using the Tether Anchor with the seat belt to attach a forward facing child restraint?	Weight limit of the Child Restraint	Always use the tether anchor when using the seat belt to install a forward facing child restraint, up to the recommended weight limit of the child restraint.
Can the rear-facing child restraint touch the back of the front passenger seat?	Yes	The child seat may touch the back of the front passenger seat if the child restraint manufacturer also allows contact. See your child restraint Owner’s Manual for more information.
Can the head restraints be removed?	Yes	All adjustable head restraints may be removed.
Can the buckle stalk be twisted to tighten the seat belt against the seat belt path of the child restraint?	Yes	In positions with cinching latch plates (CINCH), the buckle stalk may be twisted up to 3 full turns.

2005–2007 MODEL YEARS: CHRYSLER TOWN & COUNTRY/DODGE CARAVAN/DODGE GRAND CARAVAN

LATCH And Tethers In Your Vehicle

LATCH Positions For Installing Child Restraints In This Vehicle

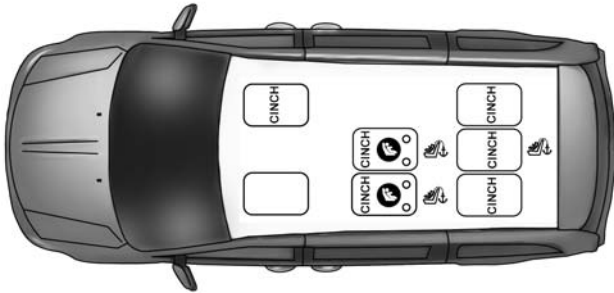

0226074934

2nd Row Bench Seat – Non-Stow ‘n Go

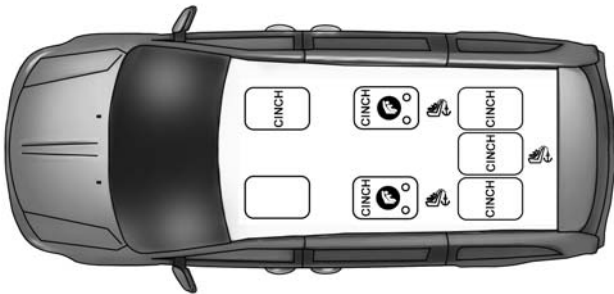

0226074936

2nd Row Quad Seating – Non-Stow ‘n Go

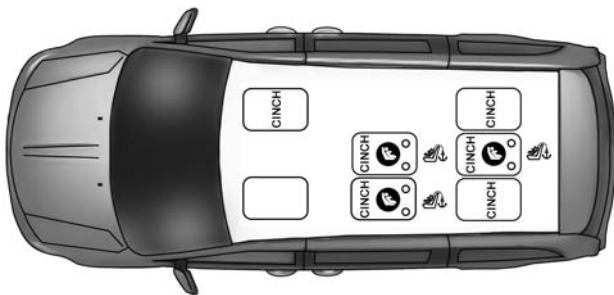

0226074937

2nd Row Bench Seat – Stow ‘n Go

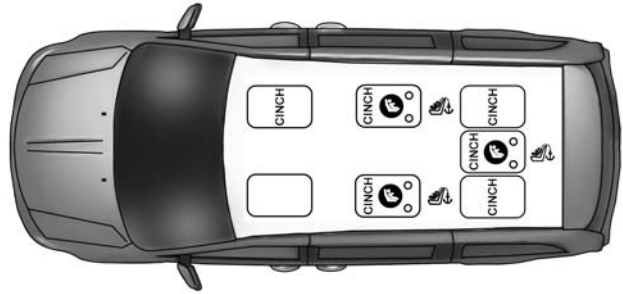

0226074939

2nd Row Quad Seating – Stow ‘n Go

- Lower Anchorage Symbol (2 Anchorages Per Seating Position)
- Top Tether Anchorage Symbol

Locating The LATCH Lower Anchorages In This Vehicle



0226074419

2nd Row Bench Seat LATCH Lower Anchorages

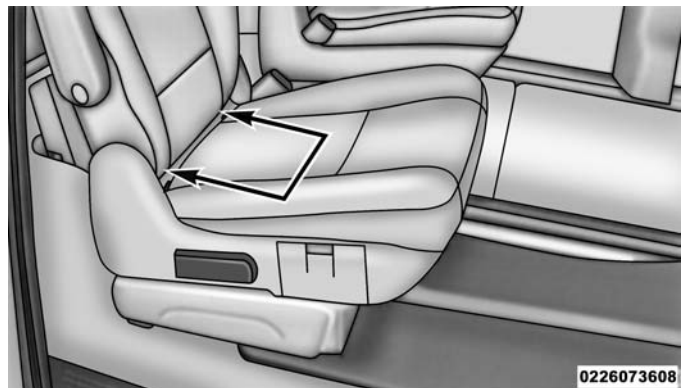

0226073608

2nd Row Quad Seat LATCH Lower Anchorages

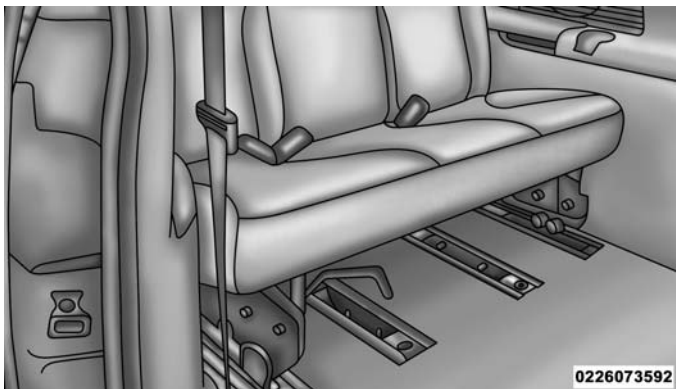

3rd Row Bench Seat Has No LATCH Lower Anchorages – Non-Stow 'n Go

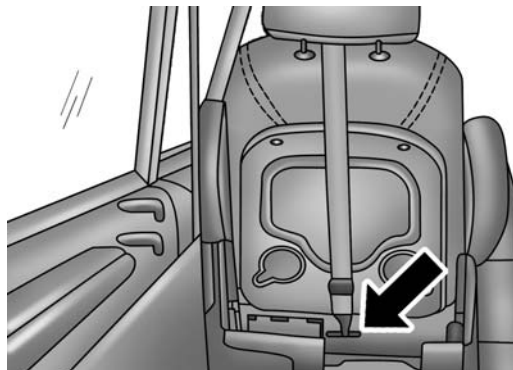

0226074425

2nd Row Quad Seat Tether Strap Anchorage

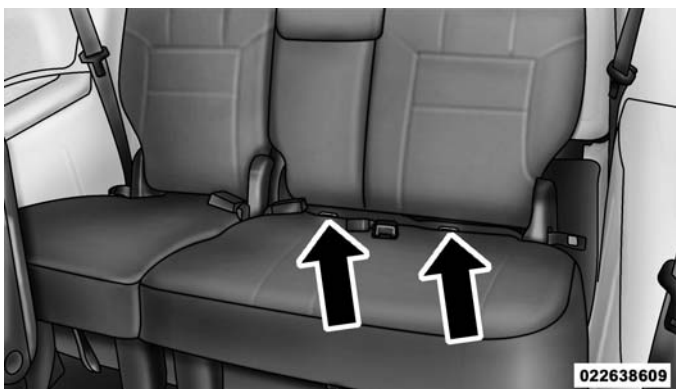

022638609

3rd Row Bench Seat LATCH Lower Anchorage – Stow 'n Go

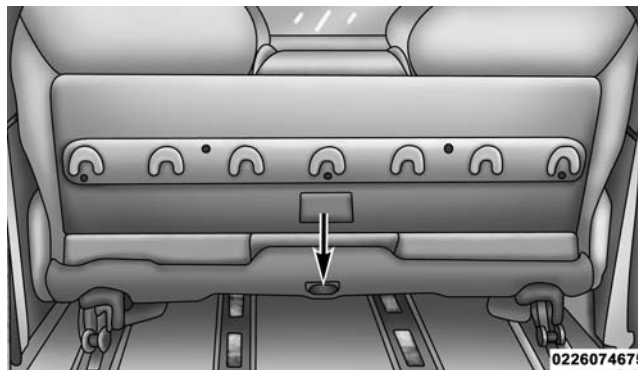

0226074675

3rd Row Bench Seat Tether Strap Anchorage

Locating The Tether Anchorages In This Vehicle

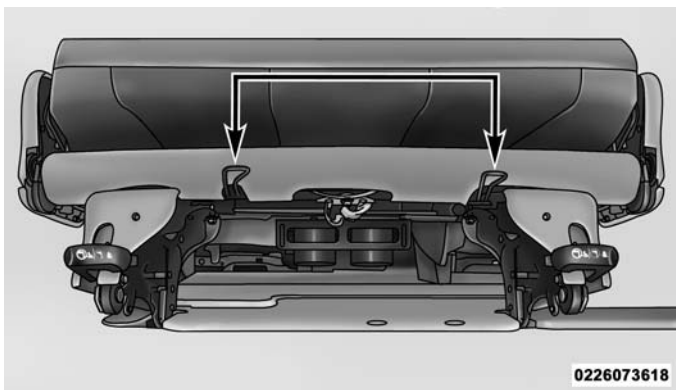

0226073618

2nd Row Bench Seat Tether Strap Anchorages

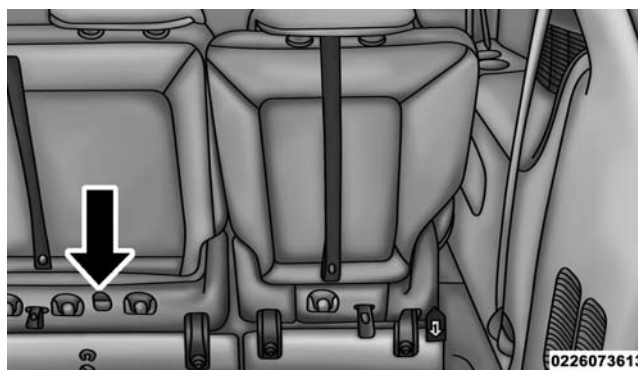

0226073613

3rd Row 60/40 Seat Tether Strap Anchorage

Frequently Asked Questions About LATCH

What is the weight limit (child's weight + weight of the child restraint) for using the LATCH anchorage system to attach the child restraint?	65 pounds	Use the LATCH anchorage system until the combined weight of the child and the child restraint is 65 lbs (29.5 kg). Use the seat belt and tether anchor instead of the LATCH system once the combined weight is more than 65 lbs (29.5 kg).
Can the LATCH anchorages and the seat belt be used together to attach a rear-facing or forward-facing child restraint?	No	Do not use the seat belt when you use the LATCH anchorage system to attach a rear-facing or forward-facing child restraint.

Frequently Asked Questions About LATCH

Can two child restraints be attached using a common lower LATCH anchorage?	No	Never “share” a LATCH anchorage with two or more child restraints. If the center position does not have dedicated LATCH lower anchorages, use the seat belt to install a child seat in the center position next to a child seat using the LATCH anchorages in an outboard position.
Can the rear-facing child restraint touch the back of the front passenger seat?	No	Contact between the front passenger seat and a child restraint can affect the passenger air bag suppression system. See the vehicle Owner’s Manual for more information about the occupant classification system in your vehicle.
Can the head restraints be removed? (Non-Stow ‘n Go Equipped Vehicles)	Yes	Non-Stow ‘n Go Seats: All adjustable head restraints may be removed.
Can the head restraints be removed? (Stow ‘n Go Equipped Vehicles)	No	Stow ‘n Go Seats: Head restraints are not removable.

Center Seat LATCH — With Stow ‘n Go

If a child restraint installed in the center position blocks the seat belt webbing or buckle for the outboard position, do not use that outboard position. If a child seat in the center position blocks the outboard LATCH anchors or seat belt, do not install a child seat in that outboard position.

WARNING!

Never use the same lower anchorage to attach more than one child restraint. Please refer to “Installing The LATCH-Compatible Child Restraint System” for typical installation instructions.

Connecting The Top Tether Strap (With Either Lower Anchors Or Vehicle Seat Belt)

When installing a forward-facing child restraint, always secure the top tether strap, up to the tether anchor weight limit, whether the child restraint is installed with the lower anchors or the vehicle seat belt.

1. Look behind the seating position where you plan to install the child restraint to find the tether anchorage. You may need to move the seat forward to provide better access to the tether anchorage. If there is no top tether anchorage for that seating position, move the child restraint to another position in the vehicle if one is available.

2. Route the tether strap to provide the most direct path for the strap between the anchor and the child seat. If your vehicle is equipped with adjustable rear head restraints, raise the head restraint, and where possible, route the tether strap under the head restraint and between the two posts. If not possible, lower the head restraint and pass the tether strap around the outboard side of the head restraint.
3. Attach the tether strap hook of the child restraint to the top tether anchorage.
4. Remove slack in the tether strap according to the child restraint manufacturer’s instructions.

WARNING!

- An incorrectly anchored tether strap could lead to increased head motion and possible injury to the child. Use only the anchorage position directly behind the child seat to secure a child restraint top tether strap.
- If your vehicle is equipped with a split rear seat, make sure the tether strap does not slip into the opening between the seatbacks as you remove slack in the strap.

Seat Belt Systems In Your Vehicle

Lap/Shoulder Belt Systems For Installing Child Restraints In This Vehicle

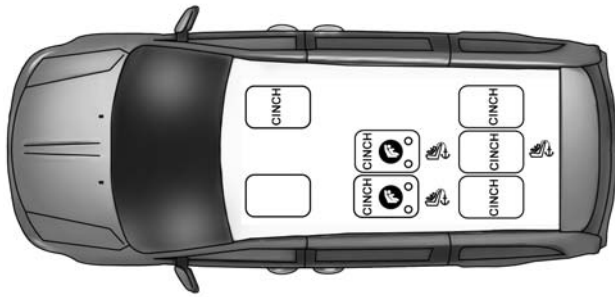

0226074934

2nd Row Bench Seat – All Positions CINCH, 3rd Center CINCH Lap Belt

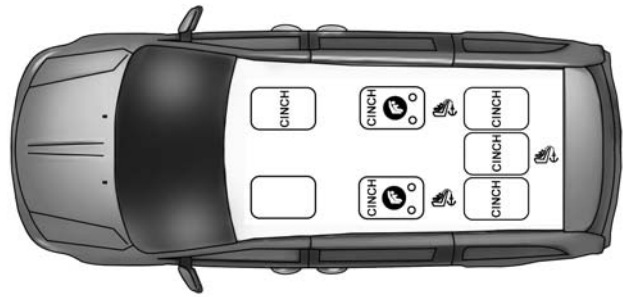

0226074936

2nd Row Quad Seating – All Positions CINCH, 3rd Center CINCH Lap Belt

Frequently Asked Questions About Seat Belts And Car Seats

What is the weight limit (child’s weight + weight of the child restraint) for using the Tether Anchor with the seat belt to attach a forward facing child restraint?	Weight limit of the Child Restraint	Always use the tether anchor when using the seat belt to install a forward facing child restraint, up to the recommended weight limit of the child restraint.
Can the rear-facing child restraint touch the back of the front passenger seat?	No	Contact between the front passenger seat and a child restraint can affect the passenger air bag suppression system. See the vehicle Owner’s Manual for more information about the occupant classification system in your vehicle.
Can the head restraints be removed? (Non-Stow ‘n Go Equipped Vehicles)	Yes	Non-Stow ‘n Go Seats: All adjustable head restraints may be removed.
Can the head restraints be removed? (Stow ‘n Go Equipped Vehicles)	No	Stow ‘n Go Seats: Head restraints are not removable.
Can the buckle stalk be twisted to tighten the seat belt against the seat belt path of the child restraint?	Yes	In positions with cinching latch plates (CINCH), the buckle stalk may be twisted up to 3 full turns.

2008–2015 MODEL YEARS: CHRYSLER TOWN & COUNTRY/DODGE GRAND CARAVAN

LATCH And Tethers In Your Vehicle

LATCH Positions For Installing Child Restraints In This Vehicle

Locating The LATCH Lower Anchorages In This Vehicle

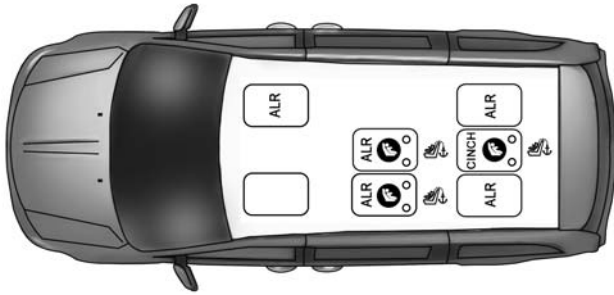

0226074942

2nd Row Bench Seat – Non-Stow ‘n Go

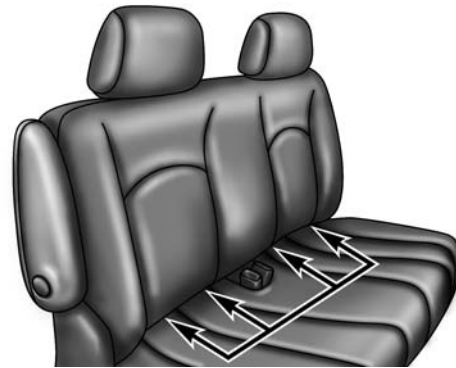

0226073614

2nd Row Bench Seat LATCH Lower Anchorages

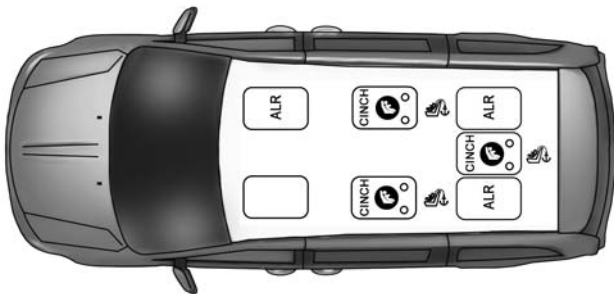

0226074944

2nd Row Swivel ‘n Go Seating

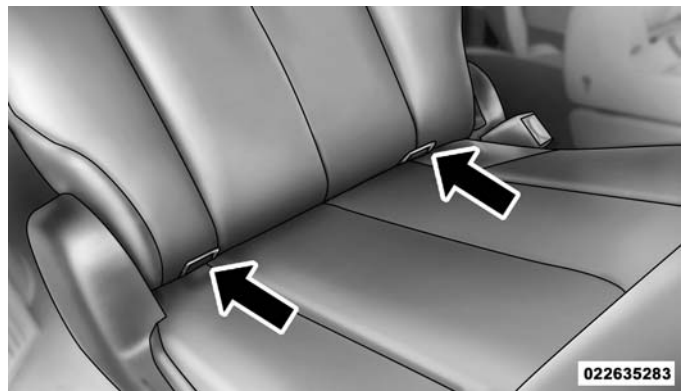

022635283

2nd Row Quad Seat LATCH Lower Anchorages

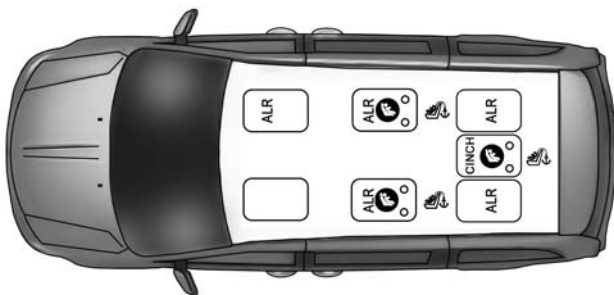

0226074943

2nd Row Quad Seating – Same For Stow ‘n Go And Non Stow ‘n Go

- Lower Anchorage Symbol (2 Anchorages Per Seating Position)
- Top Tether Anchorage Symbol

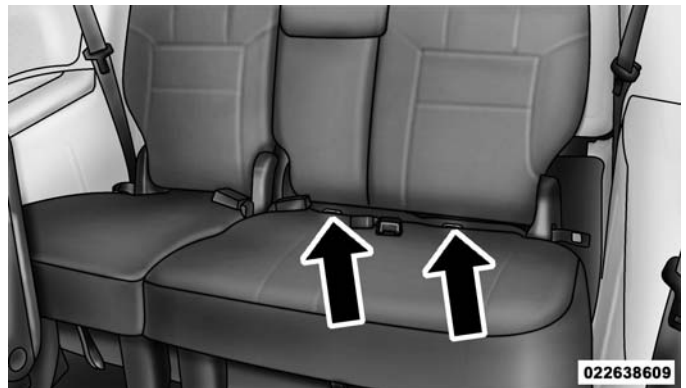

022638609

3rd Row 60/40 Seat LATCH Lower Anchorages

Locating The Tether Anchorages In This Vehicle

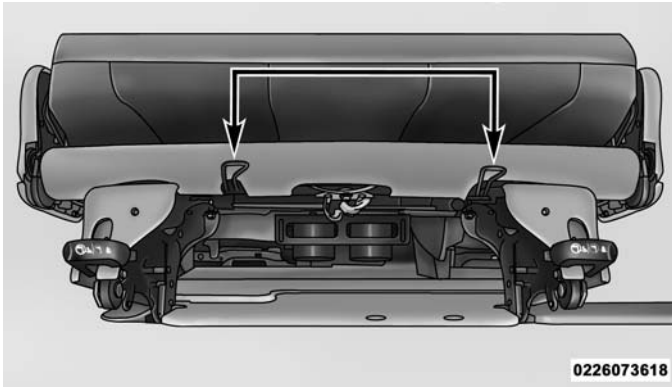

2nd Row Bench Seat Tether Strap Anchorages

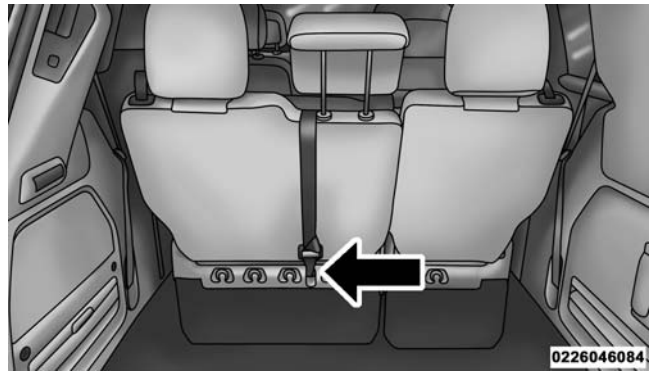

3rd Row 60/40 Tether Strap Anchorages

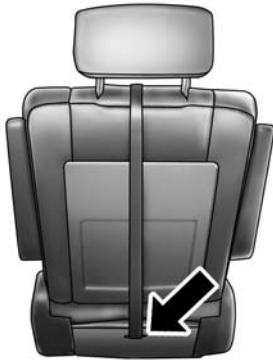

2nd Row Quad Seat Tether Strap Anchorages

Frequently Asked Questions About LATCH		
What is the weight limit (child's weight + weight of the child restraint) for using the LATCH anchorage system to attach the child restraint?	65 pounds	Use the LATCH anchorage system until the combined weight of the child and the child restraint is 65 lbs (29.5 kg). Use the seat belt and tether anchor instead of the LATCH system once the combined weight is more than 65 lbs (29.5 kg).
Can the LATCH anchorages and the seat belt be used together to attach a rear-facing or forward-facing child restraint?	No	Do not use the seat belt when you use the LATCH anchorage system to attach a rear-facing or forward-facing child restraint.
Can two child restraints be attached using a common lower LATCH anchorage?	No	Never "share" a LATCH anchorage with two or more child restraints. If the center position does not have dedicated LATCH lower anchorages, use the seat belt to install a child seat in the center position next to a child seat using the LATCH anchorages in an outboard position.
Can the rear-facing child restraint touch the back of the front passenger seat?	Yes	The child seat may touch the back of the front passenger seat if the child restraint manufacturer also allows contact. See your child restraint Owner's Manual for more information.
Can the head restraints be removed? (Non-Stow 'n Go Equipped Vehicles)	Yes	Second row and the third row center head restraints are removable.
Can the head restraints be removed? (Stow 'n Go Equipped Vehicles)	Yes	Only the third row center head restraint is removable.

NOTE: 2011-2015 Model Years: If the folding, non-adjustable head restraint interferes with the installation of the child restraint, the head restraint may be folded and the child seat installed in front of it.

WARNING!

Always make sure the head restraint is in its upright position when the seat is to be used by an occupant who is not in a child restraint. Sitting in a seat with the head restraint in its lowered position could result in serious injury or death in a collision.

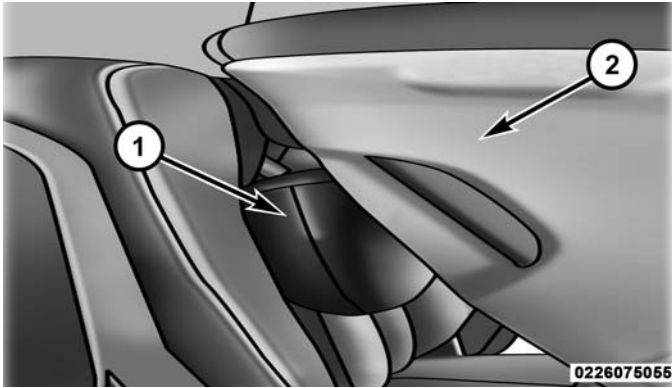

Car Seat With Head Restraint Folded

- 1 – Folded Headrest
2 – Child Restraint

Center Seat LATCH

If a child restraint installed in the center position blocks the seat belt webbing or buckle for the outboard position, do not use that outboard position. If a child seat in the center position blocks the outboard LATCH anchors or seat belt, do not install a child seat in that outboard position.

WARNING!

Never use the same lower anchorage to attach more than one child restraint. Please refer to “Installing The LATCH-Compatible Child Restraint System” for typical installation instructions.

Connecting The Top Tether Strap (With Either Lower Anchors Or Vehicle Seat Belt)

When installing a forward-facing child restraint, always secure the top tether strap, up to the tether anchor weight limit, whether the child restraint is installed with the lower anchors or the vehicle seat belt.

1. Look behind the seating position where you plan to install the child restraint to find the tether anchorage. You may need to move the seat forward to provide better access to the tether anchorage. If there is no top tether anchorage for that seating position, move the child restraint to another position in the vehicle if one is available.
2. Route the tether strap to provide the most direct path for the strap between the anchor and the child seat. If your vehicle is equipped with adjustable rear head restraints, raise the head restraint, and where possible, route the tether strap under the head restraint and between the two posts. If not possible, lower the head restraint and pass the tether strap around the outboard side of the head restraint.
3. Attach the tether strap hook of the child restraint to the top tether anchorage.
4. Remove slack in the tether strap according to the child restraint manufacturer’s instructions.

WARNING!

- An incorrectly anchored tether strap could lead to increased head motion and possible injury to the child. Use only the anchorage position directly behind the child seat to secure a child restraint top tether strap.
- If your vehicle is equipped with a split rear seat, make sure the tether strap does not slip into the opening between the seatbacks as you remove slack in the strap.

Seat Belt Systems In Your Vehicle

Lap/Shoulder Belt Systems For Installing Child Restraints In This Vehicle

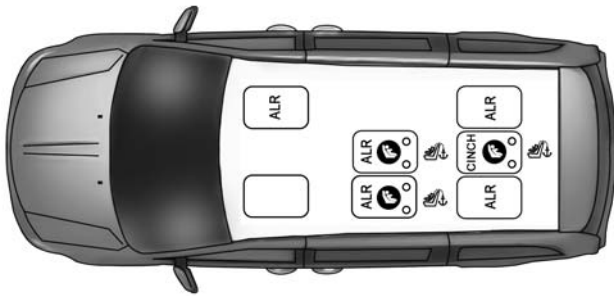

0226074942

2nd Row Bench Seat – All ALR Except 3rd Center CINCH

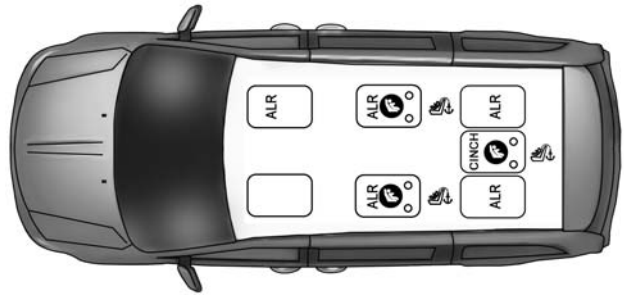

0226074943

2nd Row Quad Seating – All ALR Except 3rd Center CINCH

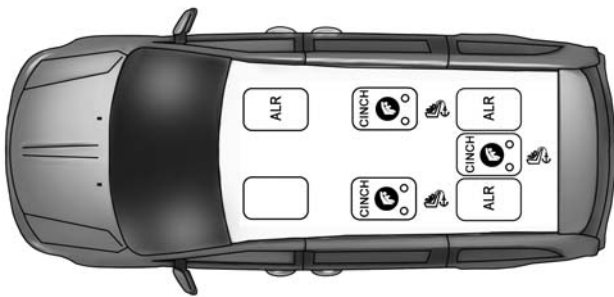

0226074944

2nd Row Swivel 'n Go Seating

Frequently Asked Questions About Seat Belts And Car Seats		
What is the weight limit (child's weight + weight of the child restraint) for using the Tether Anchor with the seat belt to attach a forward facing child restraint?	Weight limit of the Child Restraint	Always use the tether anchor when using the seat belt to install a forward facing child restraint, up to the recommended weight limit of the child restraint.
Can the rear-facing child restraint touch the back of the front passenger seat?	Yes	The child seat may touch the back of the front passenger seat if the child restraint manufacturer also allows contact. See your child restraint Owner's Manual for more information.
Can the head restraints be removed? (Non-Stow 'n Go Equipped Vehicles)	Yes	Non-Stow 'n Go Seats: Second row and third row center head restraints are removable.
Can the head restraints be removed? (Stow 'n Go Equipped Vehicles)	Yes	Second Row Bench, Quad Seats and the third row center head restraints are removable.
Can the buckle stalk be twisted to tighten the seat belt against the seat belt path of the child restraint?	Yes	In positions with cinching latch plates (CINCH), the buckle stalk may be twisted up to 3 full turns. Do not twist the buckle stalk in a seating position with an ALR retractor.

Integrated Child Booster Seat — If Equipped

The Integrated Child Booster Seat (if equipped) is located in each second-row passenger seat. The booster seat is designed for children weighing between 48 and 85 lbs (22 and 39 kg) and between 47 in (119 cm) and 57 in (145 cm) tall.

The booster seat is designed to raise the child high enough to use the vehicle lap and shoulder belt. The booster seat latch release handle is located at the front of the seat cushion.

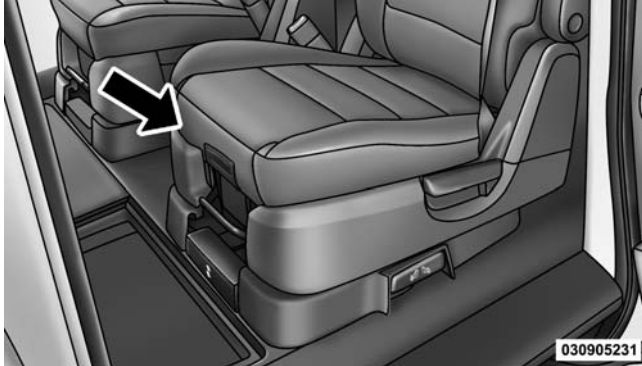

Booster Seat Release Handle

1. Pull the release handle forward to release the latch and seat cushion. Then, lift seat cushion up and push back to lock it in the booster seat position.

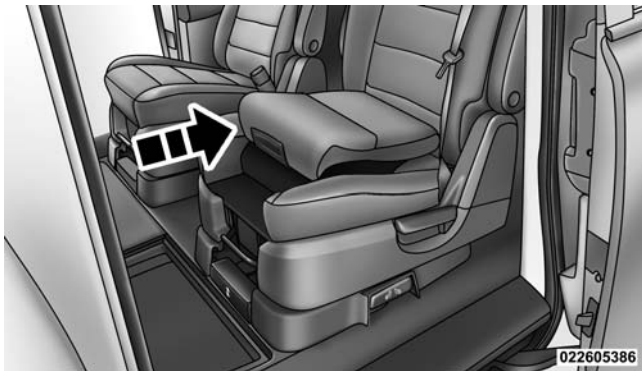

Booster Seat Position

2. Place the child upright in the seat with their back firmly against the seatback.
3. Grasp the latch plate and pull out the seat belt.
4. Slide the latch plate up the webbing as far as necessary to allow the seat belt to go around the child's lap.

NOTE: The lap portion of the seat belt should be low on the hips and as snug as possible.

5. Once the seat belt is long enough to fit properly, insert the latch plate into the buckle until you hear a "click."
6. To remove the slack from the lap belt, pull upward on the shoulder portion of the seat belt.



022605388

Integrated Child Booster Seat

7. To release the seat belt, push the red button on the buckle.

WARNING!

Failure to comply with the following conditions could result in serious injury or death:

- The swivel seat should be locked in the forward facing position when using the booster seat with the vehicle in motion.
- Be certain that the seat cushion is locked securely into position before using the seat. Otherwise, the seat will not provide the proper stability for child seats and/or passengers. An improperly latched seat cushion could cause serious injury or death.

INDEX

- Automatic Locking Retractor (ALR) 6
- Center Seat LATCH. 6, 15, 22, 26
- Child Restraints 5
- Connecting The Top Tether Strap 15, 18, 22, 26
- Frequently Asked Questions About LATCH . . 14, 17, 20, 24
- Frequently Asked Questions About Seat Belts
And Car Seats 16, 19, 23, 27
- How To Stow An Unused ALR Seat Belt. 6
- Installing A Child Restraint With A Cinching
atch Plate. 6
- Installing A Child Restraint With ALR 6
- Installing Child Restraints In Your Vehicle 1, 14
- Installing Child Restraints Using The LATCH
Lower Anchorages 5
- Installing Child Restraints Using The Top Tether
Anchorage 7
- Installing Child Restraints Using The Vehicle
Seat Belt. 6
- Integrated Child Booster Seat. 28
- Integrated Child Seat 1, 9
- LATCH And Tethers In Your Vehicle 14, 17, 20, 24
- LATCH Lower Anchorages. 14, 17, 20, 24
- Locating The LATCH And Tether Anchorages. 5
- Lower Anchors And Tether For CHildren (LATCH). 5
- Operating Instructions For Built-In (Integrated)
Child Restraint). 1, 9
- Rear Facing Car Seats And Air Bags. 5
- Seat Belt Systems In Your Vehicle 16, 19, 23, 27
- Top Tether Anchorages 7, 14, 15, 17, 18, 20, 22, 24, 26

